

# INSTALLATION INSTRUCTIONS

## RealTrim™ Treated by Woodtone

Effective: July 2019

### GENERAL INFORMATION:

RealTrim™ Treated products are designed for use in exterior applications where a textured or smooth trim or fascia product is desired.

### STORAGE

RealTrim™ Treated products must be protected from the elements at all times; preferably stored in a warehouse or covered area. At the job site keep materials off the ground, aligned on stringers and protected from the weather until used.

Material wrap is slippery when wet or frozen. To prevent injury, do not allow workers to walk on bundles.

### PRIOR TO INSTALLATION

- Consult and follow all applicable local building codes.
- RealTrim™ Treated products must be kept free from any source of moisture. As with all wood products, do not apply RealTrim™ Treated products to a structure having excessive moisture conditions or over wet building materials during the building stage.
- Do not install any defective material. Installation constitutes acceptance of the delivered material. Product installed becomes the buyer's responsibility.
- To ensure longevity, RealTrim™ Treated products must be installed following the instructions.
- RealTrim™ Treated products are graded and manufactured for the best face. This means combed face is to be installed combed face out only. If a smooth face is required, order S4S (smooth four sides) for that application.
- NOTE: Woodtone does not warrant RealTrim™ Treated when used as batten strips in a board and batten application.

### CUTTING

Use a fine-tooth hand saw or power saw with a combination blade. The cutting action of the blade should be into the face of the material. Carbide-tipped blades are recommended. Seal all end cuts with an appropriate primer/paint. See Jobsite Success booklet for additional cutting and health/safety information.

### CAULK

Caulk is required where trim and fascia abuts siding, windows, doors or other materials. Use only exterior quality caulk that remains flexible over time. Do not use hard-setting caulk.

### MACHINING

RealTrim™ Treated Fascia and Trim can be grooved or machined to provide for decorative applications. Machining depth should not exceed 5/16 of an inch for both the 1" and 7/8" products. Machining depth should not exceed 1/2 of an inch for both the 5/4 and 2" products. Routed or grooved product should not have any flat surfaces where water can accumulate. An angle of at least 100 degrees from the vertical must be maintained to provide positive drainage and not allow moisture to accumulate on the material. All machined product must be re-primed with a high-quality exterior oil or acrylic latex primer formulated for wood.

\*1" RealTrim™ Treated boards typically have a wax coating on the end of the board; Woodtone recommends cutting the ends and re-priming to ensure the paint adheres to the ends effectively. The wax is designed for temporary protection.

\*RealTrim™ Treated is not approved for top handrail applications.

### FASTENING REQUIREMENTS

RealTrim™ Treated Fascia and Trim is designed to be applied to structural framing, sheathing and other materials. It can be used in conjunction with all exterior cladding materials, including: lumber, engineered wood products, vinyl, aluminum, brick, block, concrete and stucco. Some materials require flashing separation.

For application as fascia, RealTrim™ Treated Fascia and Trim must be double nailed and fastened at a maximum 24 inches on center. For all other applications, fasten trim 24 inches apart using a staggered nailing pattern or double nail 16 inches on center.

Double nail all joints and do not nail any closer than 1/2" from the edge of material without drilling pilot holes. Use a 6d or 8d galvanized nail with a 3/16" head diameter, long enough to penetrate 1-1/4" into structural framing members. Use only corrosion resistant fasteners, such as hot dipped galvanized nails or stainless steel. Drive nails perpendicular to the framing and trim and do not overdrive or countersink the fasteners.

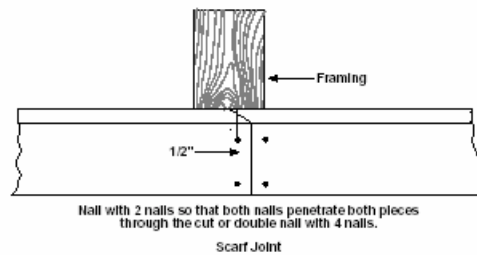
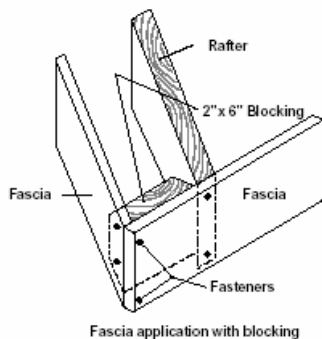

**DO NOT USE STAPLES, T-NAILS OR ANY TYPE OF COUNTER-SINKING FASTENER, such as tapered head or bugle head fasteners. Use of these fasteners will void the warranty.**

Condition	Correction
Protruding	Drive
Head slightly above surface	O.K.
Flush, head not set	None
Visible fiber, head set	Seal with paint
Countersunk 1/8" to 1/8"	Seal with exterior grade wood filler

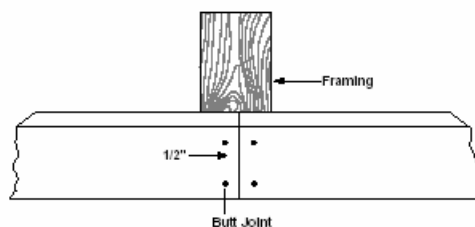

Fasten RealTrim™ Treated Fascia and Trim from one end to the other end. Do not nail towards the center from both ends.

### BUTT JOINTS:

All joints must fall over a framing member. Caulk all joints. Scarf cut on a 22.5-degree angle. Double nail all joints on both sides as noted in the diagram. In addition, gluing of joints is also recommended for finished appearance. End cuts must be re-primed.

#### **POWER DRIVEN NAILS:**

Power nailing systems are allowed when the fasteners are equal in performance (e.g., nail withdrawal, bending strength and corrosion resistance) to standard 6d or 8d nails. Any other fasteners used, such as screws or ring-shank nails, must meet the same minimum criteria.

#### **FLASHING AND MOISTURE CONTROL:**

The structure on which the RealTrim™ Treated Fascia and Trim is applied should be well vented and dry. Do not apply trim over wet sheathing, or any closer than 6 inches to finished grade or final landscaping. As with all wood products, RealTrim™ Treated Fascia and Trim should not come in direct contact with masonry or concrete and should be properly flashed and spaced at least 1/2" from any concrete flatwork or horizontal brick ledge. At foundations or exterior brick veneer, the product should be separated from the masonry by metal flashing, polyethylene film, 30 lb. Felt or a 1/4" to 1/2" air space using masonry standoffs. In all applications, Fascia and Trim should not be allowed to stand in water.

Caulk and seal the Fascia and Trim applications to prevent water intrusion. Water should not be allowed to stand on or leak behind any Trim application.

(Trim used in a horizontal application must be properly flashed as indicated in the diagram below.)

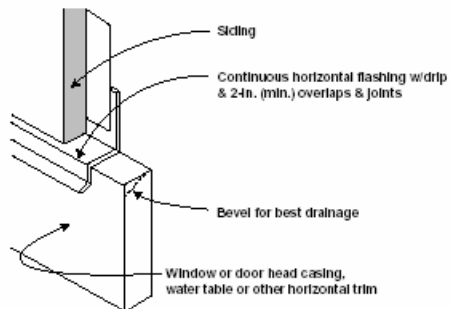

#### **FINISHING REQUIREMENTS:**

RealTrim™ Treated Fascia and Trim is manufactured from wood and must be painted with an exterior coating system in accordance with the following specifications to fulfill the warranty requirements.

#### **GENERAL INFORMATION:**

Paint performance is dependent upon the quality and quantity of paint applied, and the conditions under which it is applied. Low quality paint and/or thinly applied paint tend to last for a relatively short time, resulting in discoloration, premature fading, inadequate substrate protection, and frequent repainting – sometimes as often as every one or two years. Top quality paint, applied in sufficient quantity, will provide the best performance with the minimum maintenance. **Follow coating manufacturer recommendations when selecting and applying a paint.**

#### **SURFACE PREPARATION:**

The surface must be free of dust, dirt, mildew and other foreign materials before painting. Washing with water and a mild detergent will usually remove dust and dirt. Allow the surface to dry before painting.

**PAINT SELECTION:**

For best results, use satin/semi-gloss or full-gloss exterior acrylic latex or a satin/semi-gloss. Semi-gloss or full-gloss finishes tend to perform better than flat finishes. Note: Some systems may require the application of a designated primer and topcoat combination.

**DO NOT USE THE FOLLOWING COATINGS:**

Shake and shingle paints Vinyl acrylic paint \*  
Flat oil paint Vinyl acetate paint  
Vinyl acetate / co-polymer paint Clear Coatings  
Transparent or opaque stains

**\* Note: Although vinyl acrylic exterior paint may be readily available, it must NOT be used RealTrim™ Treated Fascia and Trim. Vinyl acrylic paint tends to weather more quickly than full acrylic paints and may discolor.**

**PAINT APPLICATION:**

Always follow the paint manufacturer's recommendations for the application and maintenance of field-applied paints.

1. Prime and paint all field-cut edges of exterior trim using high quality exterior oil or acrylic latex primer formulated for wood, or a primer recommended by the paint manufacturer.
2. All exposed surfaces including the bottom edge must be well coated. Because of its location, the bottom edge is often not adequately protected with paint. Inadequate coverage of the bottom edge may result in paint failure or premature degradation of the Fascia and Trim.
3. RealTrim™ Treated Fascia and Trim must be finished with two coats of paint within 60 days after installation. If, due to unforeseen circumstances, the material is not painted within 60 days, re-prime the trim using an exterior primer that is specifically recommended for use on wood-based products and is compatible with the topcoat to be used. Use the same primer for repair of any damage to the original factory applied primer.
4. A total field-applied dry film thickness of at least 2-1/2 mils is required on RealTrim™ Treated Fascia and Trim for the duration of the warranty period of 25 years. This requires the application of two or more non-thinned coats of paint at the spread rate recommended by the paint manufacturer.
5. Most coatings can be applied with brush, roller, pad or spray. The brush application method tends to apply the most paint per coat; spraying tends to apply the least per coat.
6. The Fascia and Trim surface temperature must not be less than 50 degrees for 24 hours following the application of water-based paint. Paint performance problems can be avoided by not applying paint in the evenings of cool spring and fall days when heavy dew can form before the surface of the paint has thoroughly dried. Allow at least 2 hours for the paint to dry before sunset. Likewise, painting in the morning should not begin until after the dew has had time to evaporate. Water absorption problems and major finish failure can occur with some latex paints when applied under these conditions.

**Woodtone is not responsible for the performance of field applied finishes. Finish performance is dependent upon coating quality and application methods which are factors controlled by the finish manufacturer and the applicator. Please follow the Care and Maintenance document to ensure performance and warranty coverage.**

**If you require further information, please contact Woodtone directly at 1-800-663-9844.**